

# OCULUS Keratograph 5M Topographer





# OCULUS Keratograph 5M

## Topographer

The multi-purpose topographer has become an integral part of the ophthalmological and optometric practice. Examiner-independent measurements provide reliable data, clear analyses and full documentation. Clear and easy-to-understand representations facilitate communication with your patients and ensure a time-saving workflow.

*"The Keratograph 5M is one of the most versatile instruments that we have in our practice. It is highly valuable and efficient for a very busy and technology-driven eye care practice such as ours."*



Barry Eiden, OD, USA

*"I use the R-Scan for contact lens fitting and documentation of ocular changes – what a helpful visual consultation tool!"*



(FH) Marc Schulze, PhD, Dipl. Eng., Canada

*"The information that I get from this instrument plays a very important role in the fitting of all forms of rigid gas-permeable contact lenses, as well as, the simple fits of everyday soft lenses."*



Chris Eksteen, DipOptom, South Africa

*"The Keratograph – with easy handling when it comes to performing meibography and excellent quality images really won me over!"*



Elisabeth Messmer, MD, Germany

*"In my clinic we use the automated pupillometry of the Keratograph for more accurate diagnosis of mild concussions. The examination takes one minute to complete. One minute for clinicians to reduce neuropsychological problems among athletes."*



Rolando Toyos, MD, USA

*"I use the Keratograph imaging tool to assess the fit of contact lenses without any additional fluorescein!"*



Sebastian Marx, Dipl. Eng., Germany

# OCULUS Keratograph 5M – The Allrounder

## Measurements With Placido Ring Illumination

White ring illumination is used to measure thousands of points on the entire corneal surface. Infrared ring illumination is also available for analyzing the tear film in order to prevent reflex tear secretion caused by glare.

## LED Measurements

The Keratograph 5M proudly offers the perfect illumination for each function: White diodes for tear film dynamics, blue diodes for fluorescein images and infrared diodes for meibography.



> white illumination



> infrared illumination



> blue diodes

## Where to find?

- Precise measurement of the corneal shape
- Extensive analyses and graphics
- Automatic keratoconus detection

- Course of disease displays
- Image and video documentation
- Measuring instruments

- Selection of contact lenses
- Fluorescein image simulation
- OxiMap®

- JENVIS Dry Eye Report
- Tear film analysis
- Meibography
- Classification of redness

- Software overview
- Network connection ability
- Technical data

Topography

Documentation

Contact Lens Fitting

Dry Eye Screening

Technology & Software

# Topography

Quick, precise and clear

Aside from topography and automatic keratoconus detection, the Keratograph 5M provides a large contact lens data base and many analyses for daily practice. The built-in keratometer and automatic measurement ensure the utmost accuracy and reproducibility. After completing the measurement, the overview display provides a detailed outline.

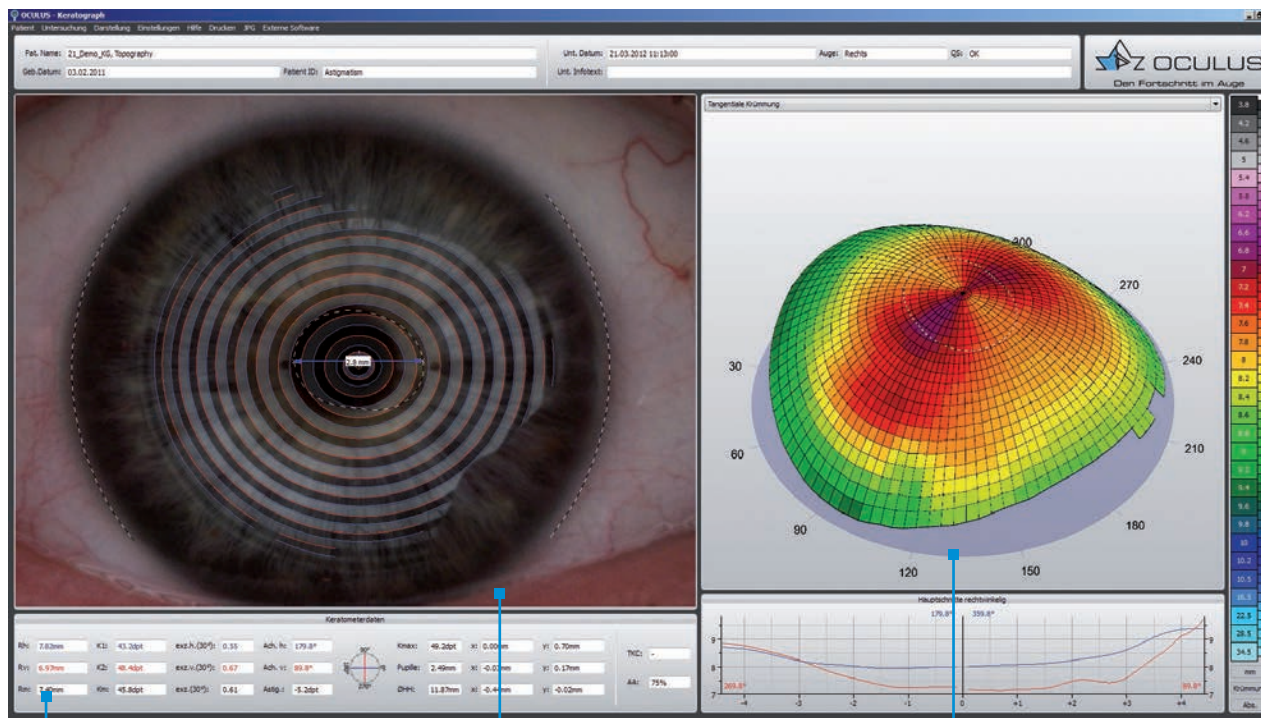

Keratometric data, diameter of the cornea and pupil, K-values and index for keratoconus detection, size of the analyzed surface

Built-in measuring instrument for measurements in the camera image

3D view can be selected and displayed directly beside the camera image

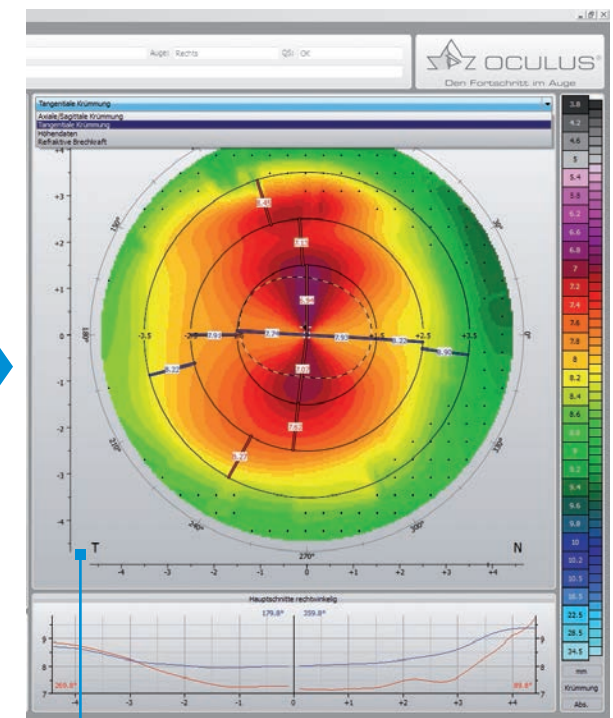

Display as sagittal or tangential curvature, elevation data or refractive power, overlay of apex position, pupil centre and contour, numerical values and major meridians



# Detailed Display of the Cornea

The Keratograph software includes a reliable screening package for corneal disease detection, lens fitting and refractive surgery. The complex corneal surface structure is measured by means of mathematical analyses, which serves as the basis accurate detection of irregularities like keratoconus. In addition, optical properties of the front surface of the cornea are exactly characterized.

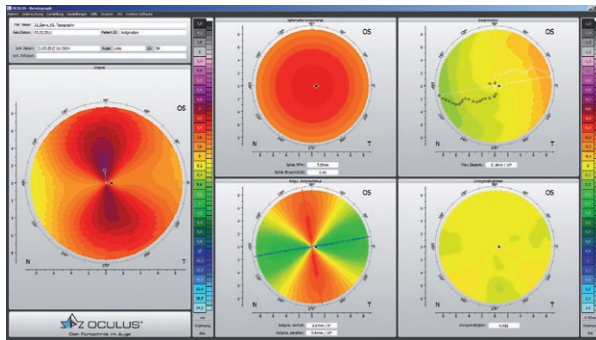

## Fourier Analysis

The refractive power of the front surface of the cornea consists of different components. The Fourier Analysis identifies four of them which are shown in the following displays:

- Spherical component
- Decentration
- Regular astigmatism
- Irregularities

Pathological changes can be quantified and possible effects on visual acuity can be explained.

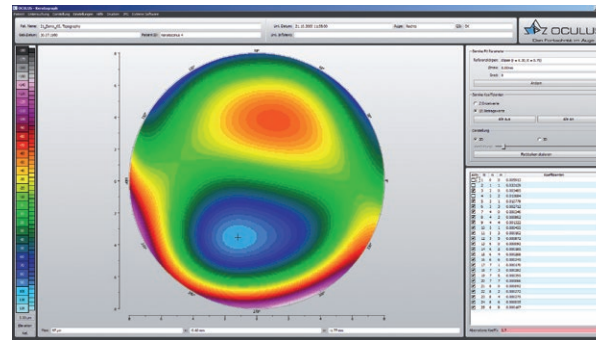

## Zernike Analysis

Zernike polynomials are adapted to the elevation data of the cornea, which is crucial for locating the apex. The apex position is labelled with a cross. This display shows you if a rear surface toric lens is applicable to the particular case. Zernike polynomials and the aberration coefficient give you important indications of the imaging quality of the corneal surface. Abnormal values are marked in colour.

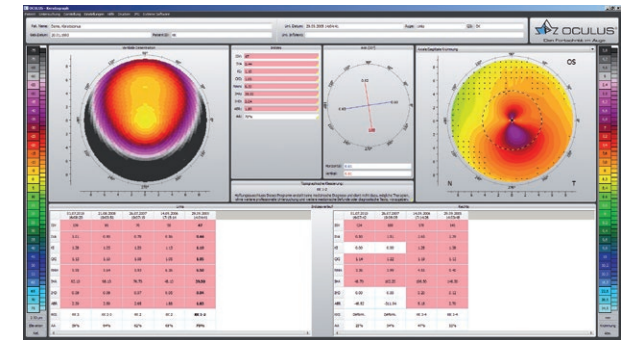

## Topographic Keratoconus Screening

Keratoconus classification is based on numerous parameters. The Topographic Keratoconus Screening display merges these parameters. The coloured label illustrates abnormal values. Temporal changes of the parameters are shown side by side in a table, to facilitate your follow-ups. The Amsler classification system is applied to the keratoconus domains.

# Complete Documentation

## Follow-ups provide reliability

Follow-ups require comparison of several examinations. In doing so, changes can be easily detected and fully documented. Regular follow-up examinations provide reliability and increase the trusting relationship between you and your patient. The Keratograph software contains both data and image documentation.

## Comparing Examinations

The Compare 3 Exams display shows changes over a certain period of time, e.g. the progressive course of disease of keratoconus. Choose between sagittal or tangential curvature and between elevation data or refractive power.

Use the Compare 2 Exams display for a right/left or before/after comparison.

The easy-to-understand displays help you describe even complex contexts to your patient.

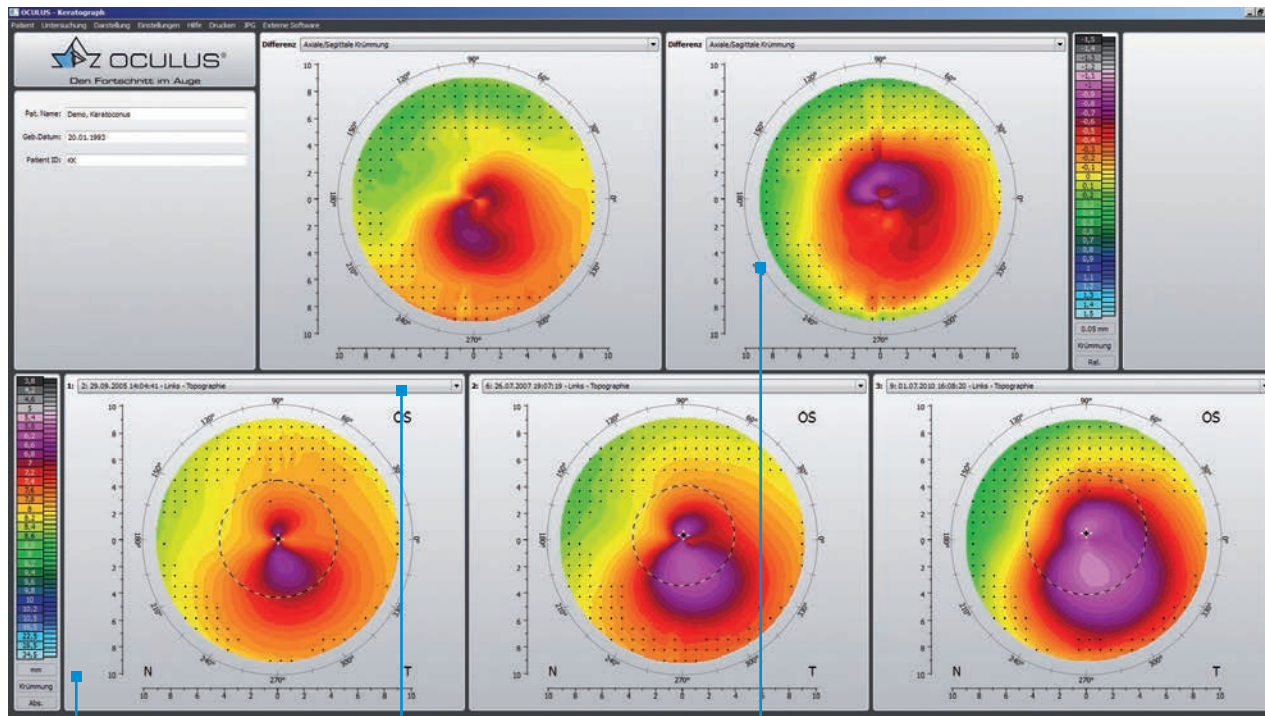

"Course of Disease" display showing three examinations

Selection of examination from the patient data base

Graphic display of differences between individual examinations. Display as sagittal or tangential curvature, elevation data or refractive power.

# A Picture Is Worth a Thousand Words.

The Keratograph 5M contains features that offer optimal conditions for your image documentation such as the high-resolution colour camera and different illumination options. An image aids in communication with education of your patients, thus eliminating the need for long explanations. You save time with only one mouse click.

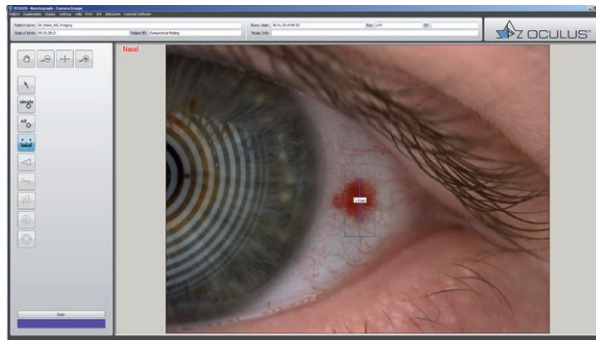

## Precise Measurements Instead of Rough Guesses

The Keratograph 5M is the ideal device for your professional documentation. The imaging software includes features such as

- magnification function
- hand tool
- measuring tool
- angle measurement

Pathological changes can be exactly localized, and changes in size can be determined. This ensures that all of your patients questions will be answered.

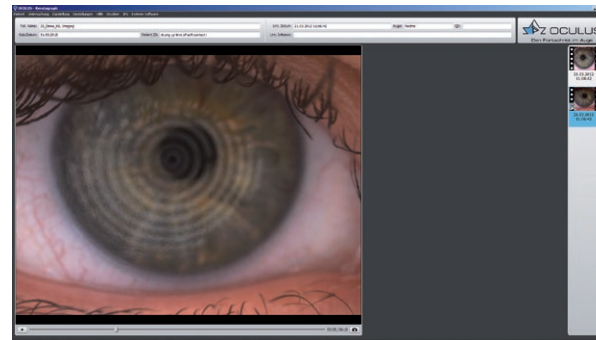

## High-Resolution Images

You can evaluate the wettability of contact lenses, without fluorescein application and determine the exact rotating of toric lenses. It is also possible to detect lipids and deposits on the lens surface, as well as corneal staining or vascularization. Show your patients images they have never seen before.

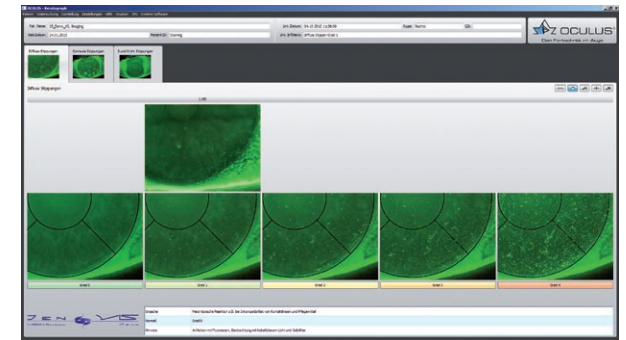

## Reliable Diagnosis Documentation

The resulting classification from corneal staining requires well-trained examiners. It is difficult to estimate the number of hyper-fluorescent dots on the corneal surface, but the integrated JENVIS Grading Scales facilitates this evaluation. Every image taken can be compared with a sample image on the screen. Vessel injections can also be evaluated and documented in this way.

# Contact Lens Fitting

Professionalism through innovation

An ideal lens is chosen from the large lens data base and is then suggested in the Lens Fitting display. Based on this topographic data, a simulated fluorescein image of this particular lens is created. You can then take real fluorescein images with the Keratograph 5M and compare them with the simulated images.

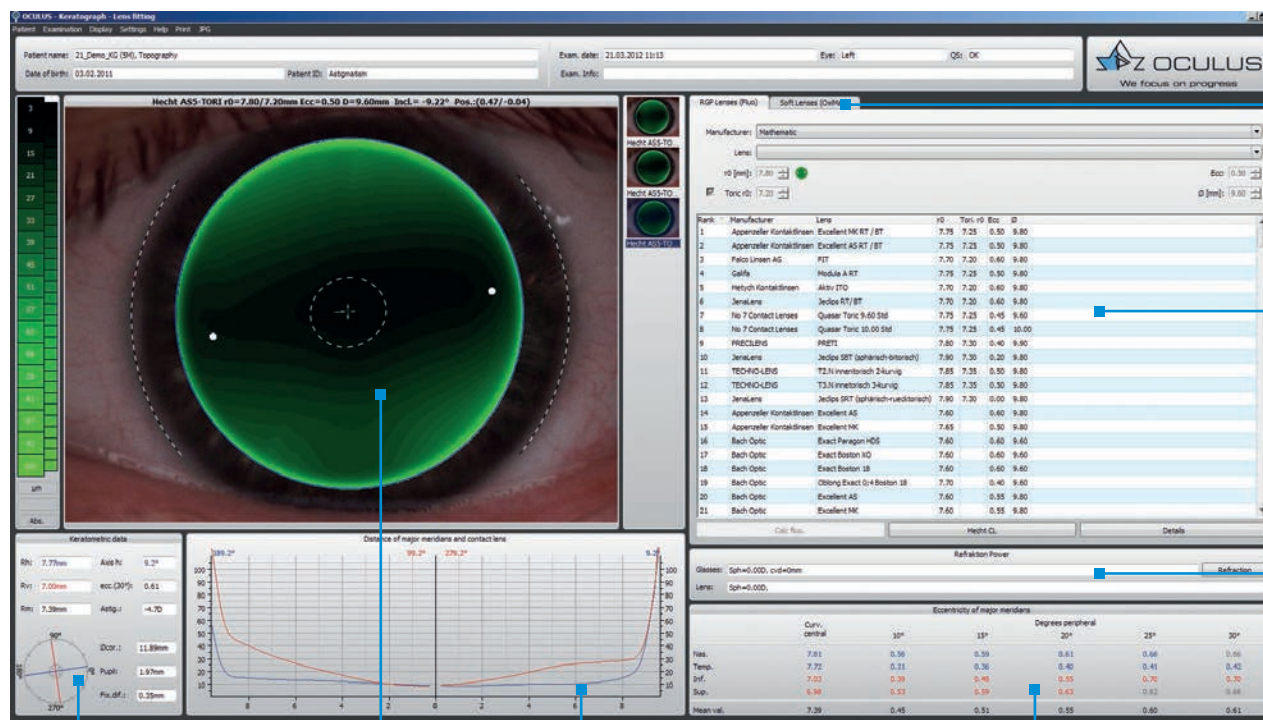

Selection between RGP and soft lenses

Contact lens suggestion from the large data base

Subjective refraction data and CVD conversion

Keratometric data, diameter of the cornea and pupil, fixation deviation

Simulated fluorescein image of a toric RGP lens

Distance of major meridians of the cornea from the lens

Eccentricity values for both major meridians



## Multifocal, Bifocal, Toric

With the Keratograph 5M you can quickly and precisely measure all of the data needed for multifocal, bifocal and toric contact lenses. These measurements also facilitate the fitting of multifocal or bifocal lenses. Furthermore the Keratograph 5M software can be linked to fitting programs of various contact lens manufacturers.

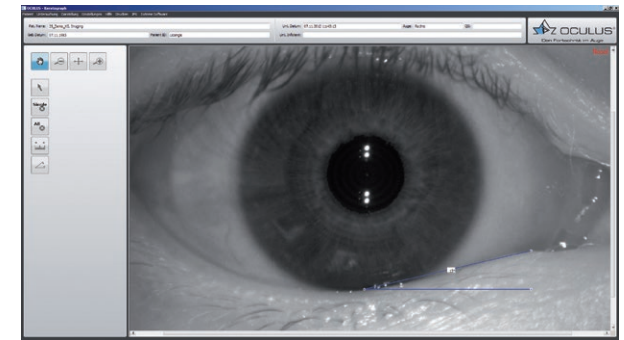
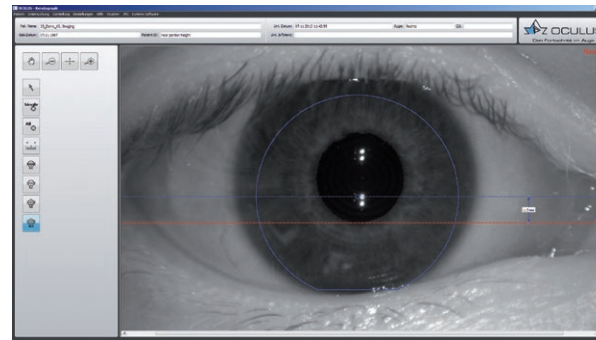
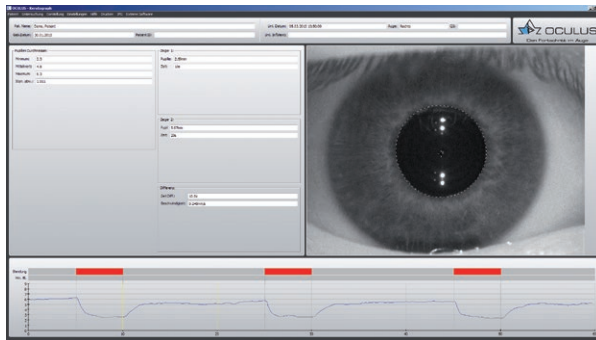

## Pupillometry

Using the "Pupillometry" option is a quick and easy way to measure the pupil size of your patients under different illumination conditions. This option not only supports you when fitting multifocal lenses, but also when measuring the optical zone before refractive or cataract surgery.

## Near-Portion Height Measurement

The near-portion height of RGP bifocal lenses can be simulated and precisely determined with this software, even before ordering the first-fitting lens. This also facilitates the complex fitting of multifocal lenses.

## Palpebral Angle Measurement

The imaginable angle of the nasal side of the lower eyelid can be measured to determine the expected nasal rotation when fitting lenses for astigmatism.

# OxiMap®

## Visualizing the oxygen transmissibility of soft lenses

An intact tear film and good oxygen supply to the cornea are essential for comfortable lens wear. The OxiMap® displays the oxygen transmissibility of soft lenses in different colours depending on the optical power and is easy to understand – even for your patients.

### Influence of Contact Lens Wearing Time

The oxygen transmissibility is an important quality criterion of soft lenses. It is indicated as Dk/t value and has a significant influence on the recommended lens wearing time. The higher the Dk/t value, the more oxygen gets through the lens to the cornea. Oxygen transmissibility changes depending on the material and the optical power of the lens.

Only measurements of oxygen transmissibility in the centre of a lens with -3.00 D have been demonstrated thus far. For the first time, the OxiMap® integrated in the Keratograph 5M displays Dk/t values over the entire surface depending on the contact lens power. You choose the lens type and the respective power. The OxiMap® is projected onto your patient's eye and you can immediately see if the selected lens is suitable for wearing overnight, for example. Explain to your patient the advantages of modern contact lenses.

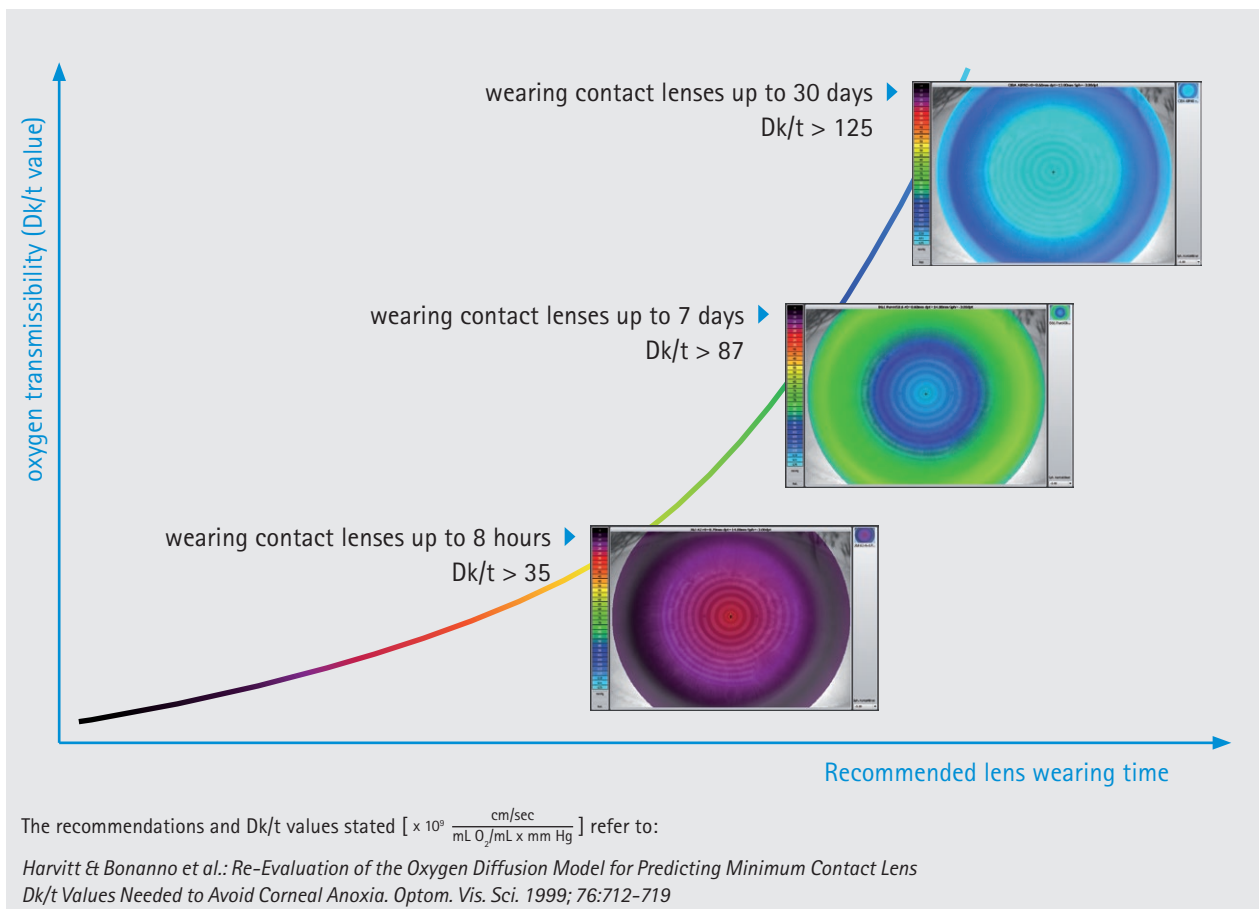





Topography

Documentation

Contact Lens Fitting

Dry Eye Screening

Technology & Software

# JENVIS Dry Eye Report

Dry eye screening made easy

Find the cause of dry eye quickly and reliably. The JENVIS Dry Eye Report is a unique tool for doing this. After measurements are taken using the Keratograph 5M and the slit lamp, your patient receives an easy-to-grasp printout. The Dry Eye Report combines screening and consultancy.

<p><b>EYECARE OPTOMETRY</b> John Doe Optometrist 123 Anywhere Street Anytown   State 12345</p> <p><b>JENVIS Dry Eye Report</b> 05.01.2015 16:42</p> <p>Patient name: 28_Demo_KG (SM), Dry Eye Report    Date of birth: 05.05.1966    Patient ID: short NIKBUT</p> <p>Right Eye (OD)    Left Eye (OS)</p> <p>Meibography, Redness, DEQ, NIKBUT, Tearmeniscus height, LIPCOP</p> <p>Normal (0.2 to &lt;0.35 mm)    Very high (&gt;0.35 mm) Very short (&lt;7 seconds)    Short (7 to &lt;11 seconds) Mild redness    Mild redness Normal    Normal Grade 0: No drop-out    Grade 0: No drop-out Grade 0: No folds    Grade 0: No folds</p> <p>JENVIS Dry Eye Report supported by OCLLUS Keratograph. OZ OCULUS</p>	<p>JENVIS Dry Eye Report    Page 2 of 3</p> <p><b>Recommendation:</b> Tear substitutes to stabilize the lipid layer.</p> <p><b>Definitions of terms used:</b></p> <p><b>Tearmeniscus height</b>    The tear quantity in a patient's eye may be estimated by measuring the height of the tear meniscus, which is the tear „prism“ that's visible between the ocular surface and the adjacent lid margin. The tear meniscus height has been determined non-invasively using infrared light. As a guideline, values of less than 0.2mm indicate a low tear quantity.</p> <p><b>NIKBUT</b>    The tear film is, among other things, responsible for reducing the friction during blinks and for maintaining the optical quality of the eye. It is therefore crucial that the tear film remains stable between blinks. A tear film that is stable for less than 10 seconds may contribute to symptoms of dry eye or a burning sensation. Insufficient tear film stability can also be reason for fluctuating vision due to there reduced optical quality.</p> <p><b>Redness</b>    Ocular redness can be caused by a number of factors, including ocular dryness, mechanical friction, allergies, contact lens solutions containing preservatives, topical medications or environmental factors. Redness levels of approximately grade 1 (on a 0 to 4 scale) are typically considered normal.</p> <p><b>DEQ OSDI</b>    The patient's perception of their ocular dryness is typically assessed by means of symptom or dry eye questionnaires. By answering specific questions related to ocular dryness symptoms, the severity of dry eye can be estimated. The classification of dry eye severity depends on the questionnaire being used.</p> <p><b>Meibography</b>    The meibomian glands are located in the upper and lower eyelid. These glands produce an oily substance that plays a crucial role in preserving the eye's tear film stability, as this oily substance helps preventing the evaporation of tears and thus symptoms of dry eye. When assessing the meibomian glands, only the gland orifices (or openings) can be seen at the lid margin with a biomicroscope. The actual glands can only be visualized by means of meibography, an imaging method using infrared light. Information about the health of the glands can further be derived from assessing the degree of capping of the gland orifices and the quality of the oily secretions.</p> <p><b>LIPCOP</b>    Using a biomicroscope at high magnification, the bulbar conjunctiva is assessed along the lower lid margin, close to the coloured part of the eye. In cases of dry eye, tiny folds that run parallel to the lid margin may be observed. These folds may form as a result of the friction that occurs on the cornea and conjunctiva during blinking. This friction is greater in cases of low tear quantity or with reduced tear film quality, which may lead to a higher number of folds.</p> <p><b>DISCLAIMER:</b> The material provided in the JENVIS Dry Eye Report is for informational purposes only. It is not intended to be a substitute for professional medical advice, diagnosis or treatment. Always seek the advice from your eye care provider with any questions you may have regarding a medical condition or treatment and before changing your current health care regimen.</p> <p>JENVIS Dry Eye Report supported by OCLLUS Keratograph. OZ OCULUS</p>	<p>Your personal logo on the Dry Eye Report</p> <p>Your personal recommendation for the patient</p> <p>Real image of the patient's eye after use of the R-Scan on the Keratograph 5M . Further images can be selected, depicting patient's meibomian glands, NIKBUT or tear meniscus height.</p> <p>The radar chart displays the 6 essential measurements for dry eye screening</p> <p>Abbreviations and technical terms are comprehensibly explained to your patient</p> <p>Individual measurements and results are presented in a clear-cut fashion</p>
--	--	---



# 3 Tools for the JENVIS Dry Eye Report – Here’s How it Works

Drawing up a comprehensive Dry Eye Report entails filling out a questionnaire, measuring the LIPCOF using the slit lamp and taking four measurements using the Keratograph 5M. Other nationally and internationally approved screening methods can be added with ease – numerous supplementary procedures ranging from eyelid blink frequency to staining are incorporated into the Keratograph 5M.

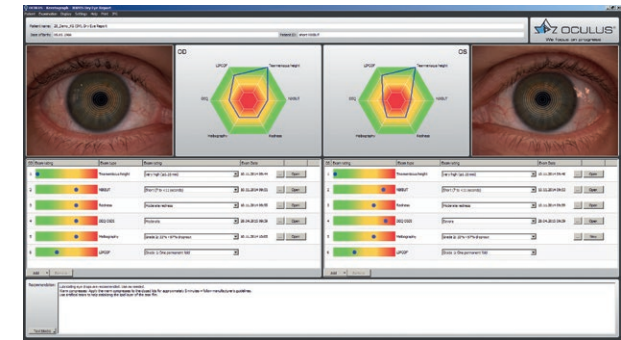
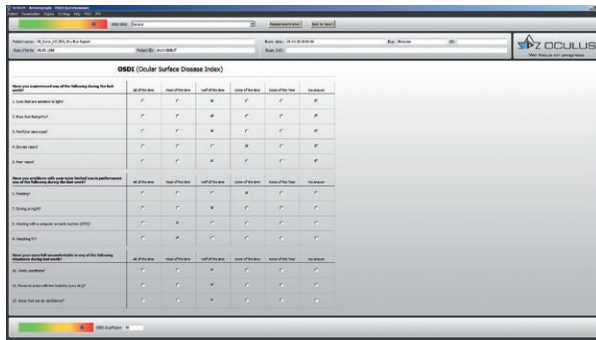

## Dry Eye Questionnaire (DEQ)

What good would a screening be without history taking? Commonly used questionnaires are incorporated into the Dry Eye Report on the Keratograph 5M.

- OSDI (Ocular Surface Disease Index)
- McM (McMonnies)

You can choose your favourite one.

## A Look Through the Slit Lamp

The slit lamp is the number one instrument when it comes to eye diagnostics.

To draw up a comprehensive Dry Eye Report it is necessary to assess the LIPCOF (lid-parallel conjunctival folds). You enter the results into the Dry Eye Report on the Keratograph 5M.

## Non-invasive Measurements

The practical tools provided by the Keratograph 5M help you perform comprehensive dry eye analysis. Analyzing the level of redness using R-Scan, measurement of tear meniscus height, tear film break-up time and meibography can all be performed with ease using the Keratograph 5M.

The result? A comprehensive Dry Eye Report.

# TF-Scan

## Evaluation of non-invasive tear film break-up time

The non-invasive tear film break-up time (NIK BUT) measures tear film stability. The NIK BUT is automatically measured within seconds, without fluorescein application. Human eyes are not able to perceive infrared illumination. Glare and reflex tear secretion are therefore avoided during the examination. The TF-Scan visualizes the results in an easy and understandable way – for you and your patients.

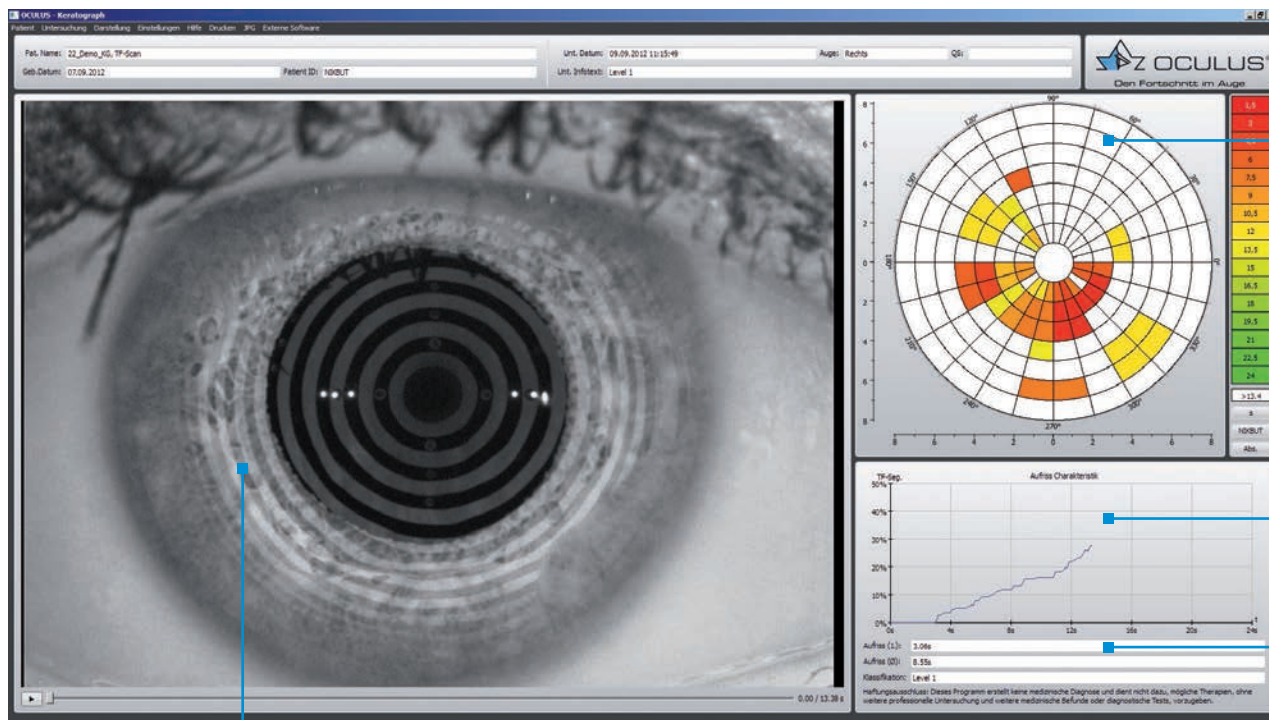

The Tear Map shows the affected areas: The respective break-up time is graphically illustrated for each segment in seconds and according to the principle of a traffic light.

The graph shows percent of the examined area that is affected during the measuring period.

Data field showing tear film break-up time (NIK BUT) in seconds and the corresponding classification.

You can watch the video after the measurement. The break-up areas detected by the software are highlighted accordingly.

# Quantity and Quality of the Tear Film

The high-resolution colour camera makes the smallest structures visible. This enables you to measure the tear meniscus height and evaluate the lipid layer, as well as analyse the tear film dynamics. Not only do you gain very important findings about tear film break-up time, but also those about the quantity and quality of the tear film.

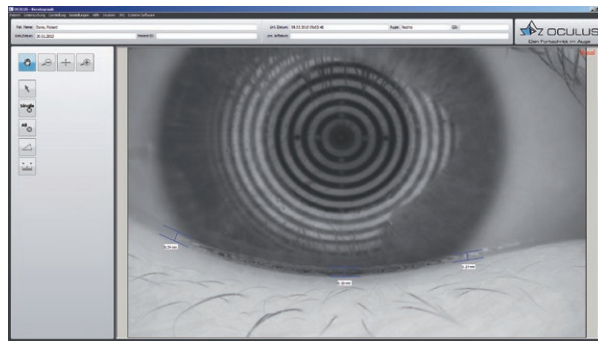

## Tear Meniscus Height

Never has a precise measurement been so easy. You can evaluate the course of the tear meniscus along the eyelid by means of the new infrared illumination and precisely measure the tear meniscus height with the built-in ruler. Different magnification levels facilitate measurement and the resulting value is automatically saved in the patient file.

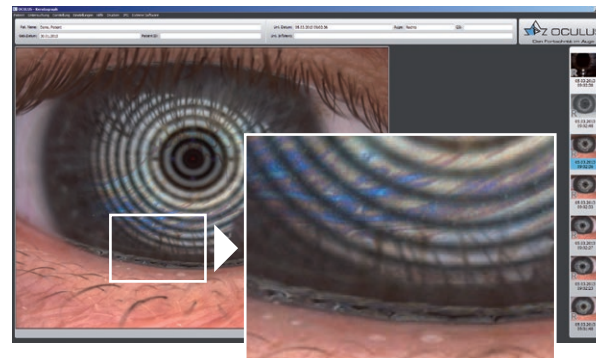

## Evaluation of Lipid Layer

Hyper-evaporative dry eye is easily overlooked when using conventional tests. Thus evaluating the lipid layer of the tear film is even more important. With the Keratograph 5M you can record videos of interference patterns of the lipid layer. Distribution characteristics, morphology and thickness of the lipid film can be continuously evaluated.



## Tear Film Dynamics

The tear film contains numerous particles. These can be made visible using a specific light source. These particles are distributed in the tear fluid from bottom to top during each blink. The velocity of these particles provides information on tear film viscosity. You can quickly and easily evaluate the quantity and movement of these tear film particles using the TF-Scan.

# Meibo-Scan

## Meibography of the upper and lower eyelid

With the multi-functional Keratograph 5M even difficult examinations such as meibography become simple to perform. It makes it easy to visualize meibomian gland dysfunction (MGD), the most frequent cause of dry eye disease. Morphological changes in the glandular tissue of the upper and lower eyelid are displayed. Up to four images from examinations of the same eyelid can be compared in a single display to assess the patient's progress.

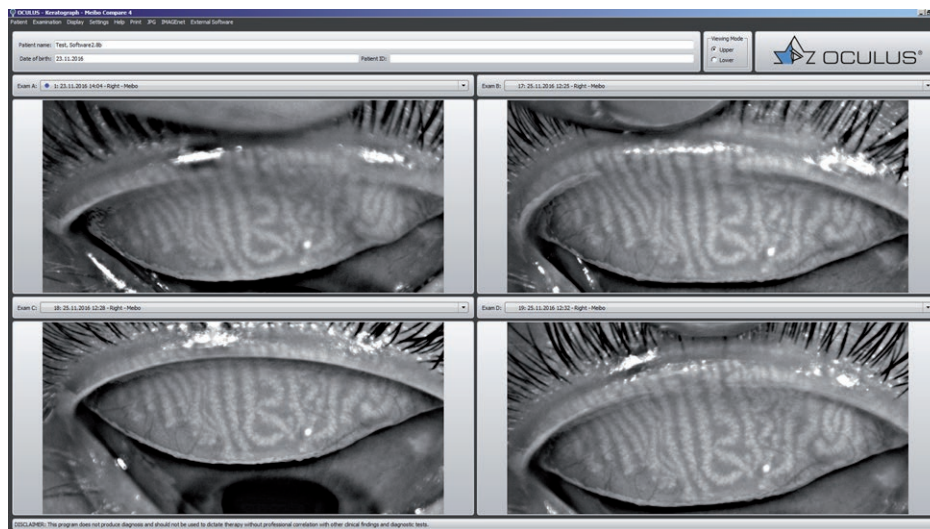

## Intuitive Comparison of Meibography Findings

The "Compare Meibo Exams" function makes it possible to assess the condition of the glandular tissue over time and hence the success of treatment. It is also helpful in communicating with and educating patients.

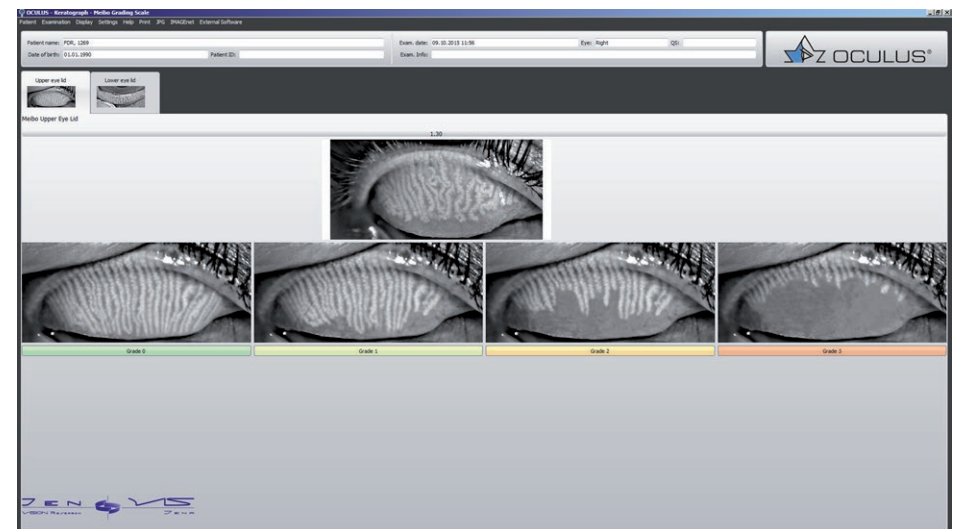

## JENVIS Grading Scales

These four-point grading scales allow easy classification of MGD based on an individual meibography. Reference-state images assist in classifying the gland structure as normal or indicative of mild or severe MGD.



# R-Scan

## Automatic classification of conjunctival redness

Previously conjunctival redness evaluation has been carried out subjectively and the results have varied according to the examiner's qualification. It is possible to objectively classify bulbar and limbal redness completely and automatically using the R-Scan. The R-Scan detects vessels in the conjunctiva and evaluates the degree of redness. Automatic classification eliminates the need for time-consuming comparison and provides greater reliability during evaluation.

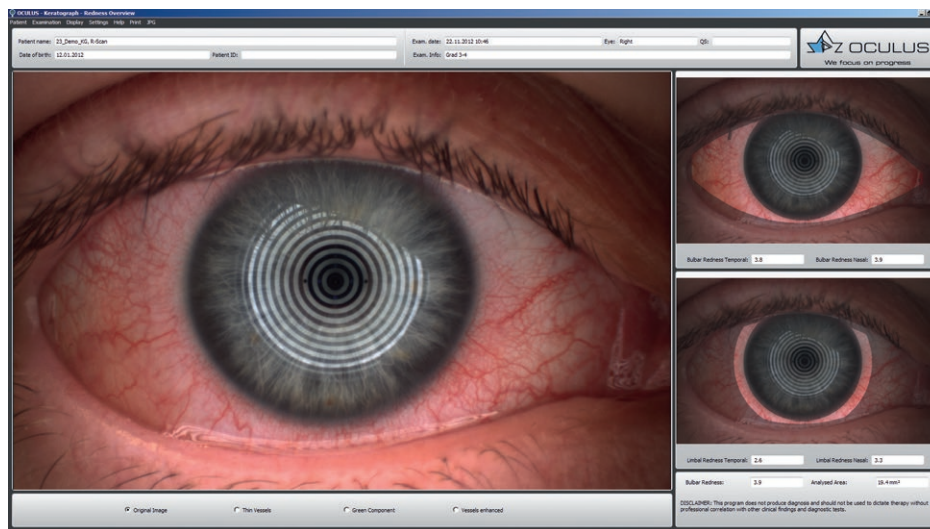

## Bulbar and Limbal Redness

Different display options help to classify the degree of redness. Choose between the camera image, view of fine vessels in the conjunctiva, red-free or contrast-enhanced display options. Bulbar and limbal redness are evaluated in the temporal and nasal areas and all results are saved automatically.

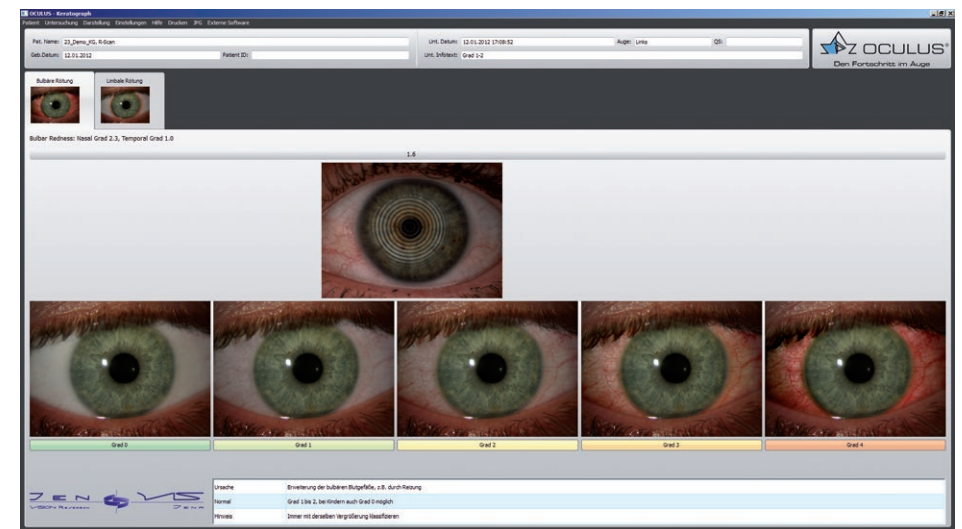

## JENVIS Grading Scales

The degree of redness is based on the JENVIS Grading Scales. The comparison of your examination results with the actual-scale images of the JENVIS Grading Scales facilitates the conversation when consulting with your patient. Further information on possible causes of redness, the normal condition as well as practical notes for capturing an image are provided below the actual-scale images.

# All Features at a Glance

Customize the OCULUS Keratograph 5M to your own requirements!

## Software included

Topography
CL Back Surface
Overview
1 Large Color Map
4 Maps Selectable
Camera Image
3D Cornea
Fourier Analysis
Zernike Analysis
Topographic Keratoconus Screening
Elevation Map
Corneal asphericity
Lens Fitting
Show 2 Exams
Compare 2 Exams
Compare 3 Exams

## Examination functions

	My wish list
TF-Scan <i>Evaluation of lipid layer and tear film dynamics, measurement of tear meniscus height and non-invasive tear film break-up time (NIK BUT)</i>	<input type="checkbox"/>
R-Scan <i>Automatic classification of bulbar and limbal redness</i>	<input type="checkbox"/>
Meibo-Scan <i>Meibography of upper and lower eyelid</i>	<input type="checkbox"/>
Pupillometry <i>Examination of pupillary response using the pupillometer, asymmetry test and manual measuring mode</i>	<input type="checkbox"/>
Imaging <i>Image and video documentation with fluorescein imaging, near-portion height measurement and eyelid angle measurement</i>	<input type="checkbox"/>

## Evaluation functions

	My wish list
JENVIS Dry Eye Report <i>Comprehensive summary display of all available dry eye tests</i>	<input type="checkbox"/>
Keratoconus package <i>Includes Topographic Keratoconus Screening and Zernike Analysis</i>	<input type="checkbox"/>
Lens Fitting <i>Simulation of fluorescein images of RGP lenses</i>	<input type="checkbox"/>
OxiMap® <i>Graphic display of oxygen transmissibility (Dk/t value) of soft lenses</i>	<input type="checkbox"/>

# Floating License Key

More flexibility with the OCULUS license model

## Activate Functions Exactly as You Need Them

The choice is yours in how you use the Keratograph 5M and which examination and evaluation functions you desire. You can order additional functions of optional evaluation functions, according to your modular design principle. After purchase, licenses for the respective evaluation functions are activated on the OCULUS Floating License Key and are provided in your network. It is possible to call and view previously performed examinations for free on all workstations within the network.

Optional examination functions
TF-Scan
R-Scan
Meibo-Scan
Pupillometry
Imaging

Optional evaluation functions
JENVIS Dry Eye Report
Keratoconus package
Lens Fitting
OxiMap®

You can decide which additional functions to allocate to each device.

## Efficiency Through Networking

The OCULUS patient data management system enables you to merge all OCULUS devices in a local network. It allows you to collaborate with external data management systems (EMR) to optimize your workflows. DICOM interface is not necessary for device connection.

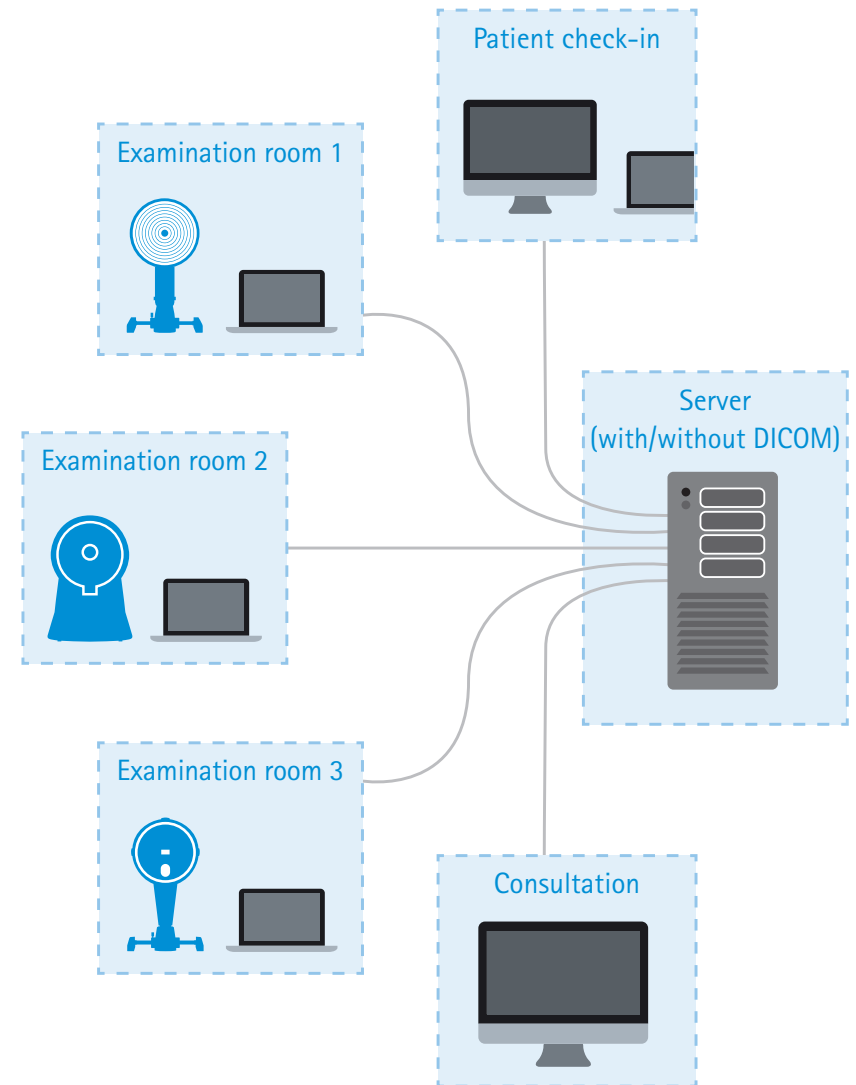

# Technical Data

## OCULUS Keratograph 5M

General information	
Precision	± 0.1 D
Reproducibility	± 0.1 D
Number of rings	22
Working distance	78 - 100 mm
Number of evaluated data points	22.000
Camera	Digital CCD camera
Illumination source	Placido illumination: white diodes Placido illumination: infrared diodes (880 nm) Imaging illumination: blue diodes (465 nm) Meibography: infrared diodes (840 nm) Tear film dynamics: white diodes Pupillometry illumination: infrared diodes (880 nm)
Technical specifications	
Dimensions (W x D x H)	275 x 320 - 400 x 485 - 512 mm (10.8 x 12.6 - 15.7 x 19.1 - 20.2 in)
Weight	Measuring equipment: 3.2 kg (7.1 lbs) With xy base: 6.1 kg (13.5 lbs)
Max. power consumption	18 W
Voltage	90 - 264 V AC
Frequency	47 - 63 Hz
Recommended computer specifications	CPU Intel® Core™ i5-6600, 500 GB HDD, 8 GB memory, Windows® 10 64 bit

CE in accordance with Medical Device Directive 93/42/EEC

WWW.OCULUS.DE



OCULUS is certified by TÜV according to  
DIN EN ISO 13485

OCULUS Optikgeräte GmbH  
Postfach • 35549 Wetzlar • GERMANY  
Tel. +49-641-2005-0 • Fax +49-641-2005-295  
Email: export@oculus.de • www.oculus.de

- OCULUS USA, sales@oculususa.com
- OCULUS Asia, info@oculus.hk
- OCULUS Czechia, oculus@oculus.cz
- OCULUS Iberia, info@oculus.es
- OCULUS Poland, biuro@oculus.pl
- OCULUS Turkey, info@oculus-turkey.com.tr

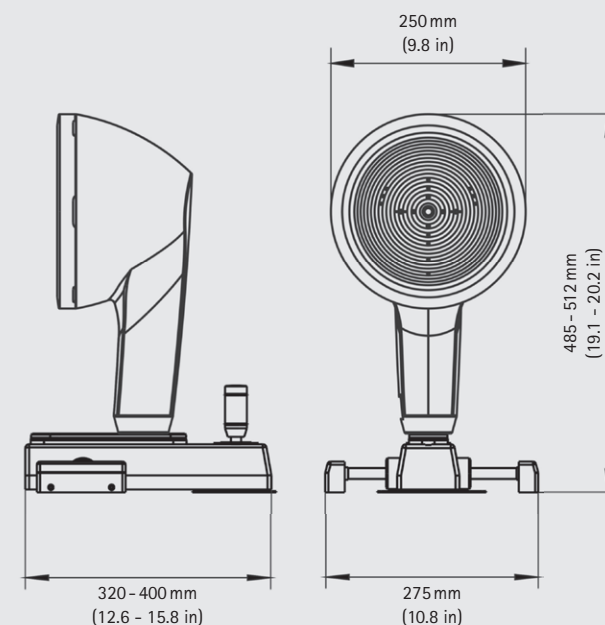

The availability of products and features may vary by country.  
OCULUS reserves the right to change product specifications and  
design. All information is valid at the time of printing (04/17)



28/0317/EN/HA  
P/77000/EN